

MINI EXCAVATOR



Specifications

Operating weight	1926 kg
Engine power	11.2 kW (15 HP)
Bucket capacity	21 - 91 l
Dig depth	2.3 / 2.45 m
Reach	3.8 / 4.06 m

Features

- ▶ Zero-tail version
- ▶ Telescopic undercarriage (990-1300 mm)
- ▶ Wide dozer blade for dozer applications
- ▶ Cab with excellent visibility, canopy optional
- ▶ Boom adjustable by 61° to the left, 69° to the right, enables excavation directly in front of walls
- ▶ Wide range of proven work attachments

SPECIFICATIONS

ENGINE

Manufacturer, model	Yanmar, 3TNV70-NPR
Type	3-cylinder diesel engine, EPA/Tier 4 Final (2008)
Combustion	4-stroke, swirl chamber injection
Displacement	854 cm ³
Power rating acc. to ISO 9249 at 2260 rpm	11.2 kW (15 HP)
Cooling system	Water

ELECTRICAL SYSTEM

Operating voltage	12 V
Battery	12 V / 65 Ah
Generator	12 V / 35 A

TRANSMISSION

Two-stage hydrostatic travel drive with axial piston variable displacement motor and reduction gear, fully enclosed.	
Travel speed, forward and reverse	0-2.2/4.2 kph
Gradeability	max. 60%
Drawbar pull	1470 daN

UNDERCARRIAGE

Maintenance-free crawler-type undercarriage. Idler suspension with hydraulic crawler track tensioning. Mechanically retractable/extendable undercarriage provided as standard.	
Width (outside edge of crawler chains)	990 / 1300 mm
Width of rubber crawlers	230 mm
Total length (sprocket - idler)	1158 mm
Total length (undercarriage)	1562 mm

DOZER BLADE

Independent of drive train, sensitive control via separate hand lever. Cylinder protection as standard.	
Width x height	990 (1300) x 240 mm
Dozer cut below ground	290 mm
Dozer lift above ground	260 mm
Slope angle	30°

STEERING

Independent, individual control of crawler chains, also counterwise. Sensitive control via hand levers combined with foot pedals. Pedal console serving as foot rest.	
---	--

SWING SYSTEM

Hydrostatic drive, also acts as wear-resistant brake. Internally toothed ring gear.	
Swing speed	0-12 rpm

KNICKMATIK®

Lateral parallel adjustment of boom arrangement at full dig depth.	
Angle of articulation / lateral adjustment left	61° / 470 mm
Angle of articulation / lateral adjustment right	69° / 570 mm

FLUID CAPACITIES

Hydraulic system (incl. 20 l tank)	30 l
Cooling system	4 l
Engine oil	2.8 l



OPERATING DATA, STANDARD EQUIPMENT

Transport weight (with canopy)	1750 kg
Transport weight (with cab)	1820 kg
Operating weight (with canopy) acc. to ISO 6016	1811 kg
Operating weight (with cab) acc. to ISO 6016	1926 kg
Total length (travel position)	2371 (2401*) mm
Total length (trailer transport position)	3300 mm
Total height (travel position)	2357 mm
Total width	990 - 1300 mm
Uppercarriage tailswing	650 mm
Uppercarriage frontswing	1640 (1670*) mm
Working envelope 180° / 360°	2340 / 3375 (2355 / 3410*) mm
Ground clearance	190 mm
Bucket digging force (ISO 6015)	15,200 N
Stick digging force (ISO 6015)	11,730 N
Ground pressure (rubber crawlers)	0.28 daN/cm ²

HYDRAULIC SYSTEM

Pump capacity	17.6 + 17.6 + 14.3 lpm
Working pressure	210 bar
Working hydraulics: Tandem-controlled dual piston variable displacement pump for all work movements and travel drive. Simultaneous independent control of all movements.	
Control circuit for work attachments (single or dual-action):	
Pump capacity	36 lpm
Max. working pressure	210 bar

CAB

Full-vision steel cab, FOPS (acc. to ISO 3449) and TOPS (acc. to ISO 12117 / EN 13531) certified.	
Heating, ventilation and seat belt.	
Radio preparation	
Instrument panel on the right hand side of the operator's seat with visual & acoustic warning device, hour-meter, instrument cluster with large fuel gauge.	
Working floodlights mounted on the boom.	
Noise emission ambience L _{WA}	93 dB (A)
Noise emission cab L _{PA}	79 dB (A)
Measured in dynamic measuring cycle acc. to EC Directive 2000/14/EC.	
*with 1350 mm dipperstick (optional)	

WORKING RANGES & DIMENSIONS: MONOBLOC BOOM

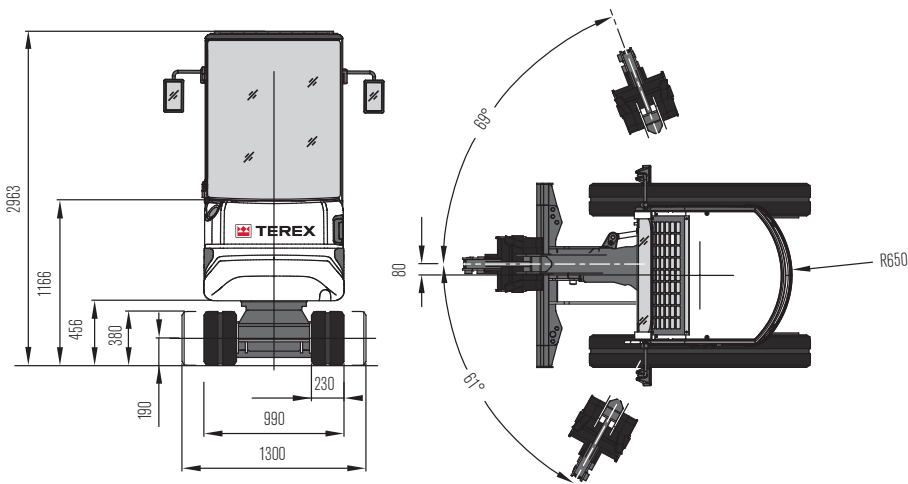
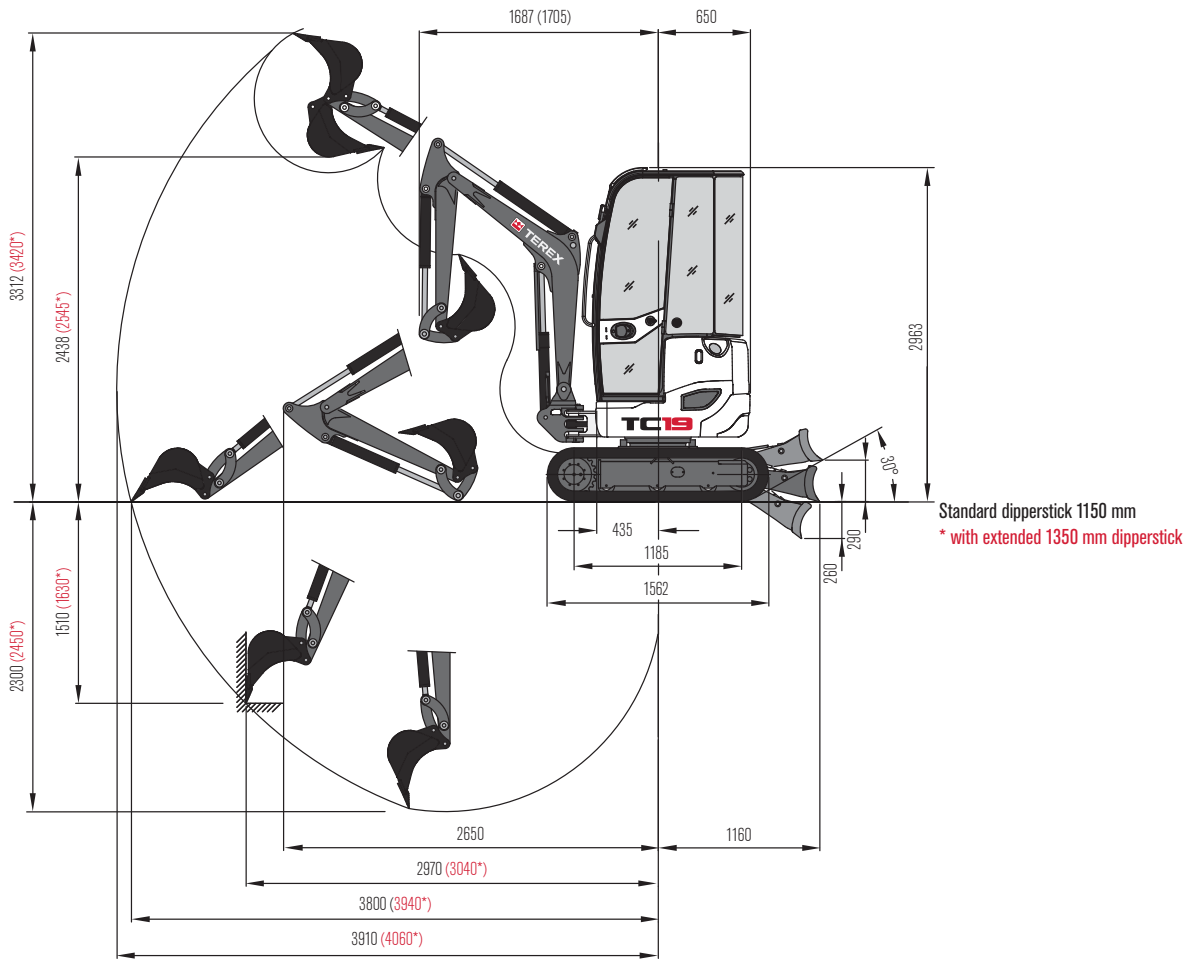

LIFTING CAPACITIES

Bucket hinge height Dipperstick 1150 mm		Load radius from centre of ring gear				
		1.5 m	2.0 m	2.5 m	3.0 m	Max.
1.0 m	A1	610	410	280	205	180
	A2	660	440	360	310	250
	L	610	410	235	160	160

All values in kilograms (kg) were determined acc. to ISO 10567 and include a stability factor of 1.33 or 87% of the hydraulic lifting capacity. All values were determined without the bucket. In case of mounted-on work attachments, the deadweights of the work attachments must be deducted from the permissible payloads.

Working equipment: Rubber crawlers.

Abbreviations: A1 = Front, supported, A2 = Front, travelling, L = Laterally rotated 90°, travelling

WORK ATTACHMENTS

BUCKETS

Bucket, QAS	250 mm wide, capacity 24 l
Bucket, directly mounted	220 mm wide, capacity 21 l
Bucket, QAS	300 mm wide, capacity 30 l
Bucket, directly mounted	300 mm wide, capacity 29 l
Bucket, QAS	400 mm wide, capacity 44 l
Bucket, directly mounted	400 mm wide, capacity 40 l
Bucket, QAS	500 mm wide, capacity 55 l
Bucket, QAS	600 mm wide, capacity 71 l
Bucket, directly mounted	600 mm wide, capacity 61 l
Ditch-cleaning bucket, QAS	1000 mm wide, capacity 91 l
Ditch-cleaning bucket, directly mounted	850 mm wide, capacity 61 l
Swing bucket, QAS (up to max. 1.0 t/m ³)	850 mm wide, capacity 61 l
Swing bucket, directly mounted	1000 mm wide, capacity 56 l

OPTIONAL EQUIPMENT

BOOM OPTIONS

Monobloc boom, with extended 1350 mm dipperstick

CRAWLER CHAIN OPTIONS

Steel crawler track, 230 mm wide

HYDRAULIC SYSTEM

Hose-rupture / load-retaining valve for boom Hose-rupture / load-retaining valve for dipperstick

OTHER WORK ATTACHMENTS

Hydraulic hammer	Quick-change adapter for hydraulic hammer
Auger	Further work attachments available on request

OPERATOR'S CANOPY

Canopy, robust steel pipe construction with 4 vertical support members and steel plate protection roof. FOPS (acc. to ISO 3449) and TOPS (acc. to ISO 12117 / EN 13531) certified. Operator's seat with artificial leather covering, seat belt.

Cab-mounted working floodlights

Yellow beacon

OTHER OPTIONAL EQUIPMENT

Mechanical quick-attach system (QAS) Additional rear weight 80 kg

Further optional equipment available on request

www.terexconstruction.com

Effective date: 1st October, 2011. Product specifications and prices are subject to change without notice or obligation. The photographs and/or drawings in this document are for illustrative purposes only. Refer to the appropriate Operator's Manual for instructions on the proper use of this equipment. Failure to follow the appropriate Operator's Manual when using our equipment or to otherwise act irresponsibly may result in serious injury or death. The only warranty applicable to our equipment is the standard written warranty applicable to the particular product. Terex makes no other warranty, express or implied. Products and services listed may be trademarks, service marks or trade-names of Terex Corporation and/or its subsidiaries in the USA and other countries. All rights are reserved. "Terex" is a registered trademark of Terex Corporation in the USA and many other countries. Copyright © 2012 Terex Corporation (R2_270212) Ref. No.: TEREX653EN

Terex Deutschland GmbH
Geschäftsbereich Compact
Kraftwerkstr. 4, D-74564 Crailsheim
Tel: +49 (0)7951 / 9357-0 Fax : +49 (0)7951 / 9357-671
construction@terex.com www.terex.com



WORKS FOR YOU.™